

Lighting fixture ROA LED White

The ROA LED wall lamp is distinguished by a modern and linear form thanks to the use of an integrated LED module. The non-standard, elongated design is ideally suited to be mounted above a bathroom mirror, a display cabinet or above a gallery of family photos. The light of a natural color falling from above will emphasize the details and highlight the play of light and shadow.

| SPECIFICATIONS | EDO777246 |
|--|------------------|
| Source Type: | mirror lamp |
| Application: | inside |
| Installation: | surface |
| Adjustable: | no |
| Dimensions [mm]: | |
| -height [mm]: | 130mm |
| -width [mm]: | 600mm |
| -depth [mm]: | 55mm |
| Colour: | black |
| Material: | aluminium, glass |
| Cover colour: | transparent |
| Energy efficiency class [A-G]: | G |
| Cooperation with a dimmer: | no |
| Dimmer: | - |
| TECHNICAL DATA | |
| Power in the on-mode P _{on} [W]: | 13W* |
| Standby power P _{sb} /P _{net} [W]: | - |
| Rated voltage [V]: | 220-240 V AC |
| Rated frequency [Hz]: | 50-60 Hz |
| Color temperature [K]: | 4000 K |
| Light color change: | no |
| Light color change [°]: | 119.4° |
| Color rendering index CRI: | < 80 |
| Color rendering index R9: | 15 |
| Luminous flux [lm]: | 900 lm |
| Measurement of the luminous flux in: | ball (360°) |
| Luminous efficiency [lm/W]: | 81,76 |
| Rated life [h]: | 25000 h |
| Number of cycles on/off: | 15000 |
| On-mode energy consumption [kWh/1000h]: | 13* |
| IP: | IP44 |
| Replaceable LED module: | no |
| Protection class: | I |
| Mercury content: | no |
| Environmental conditions [°C]: | -20°C...40°C |
| LOGISTIC DATA | |
| Collective packaging [pc]: | 20pc. |
| Weight [g]: | - |
| EAN: | |

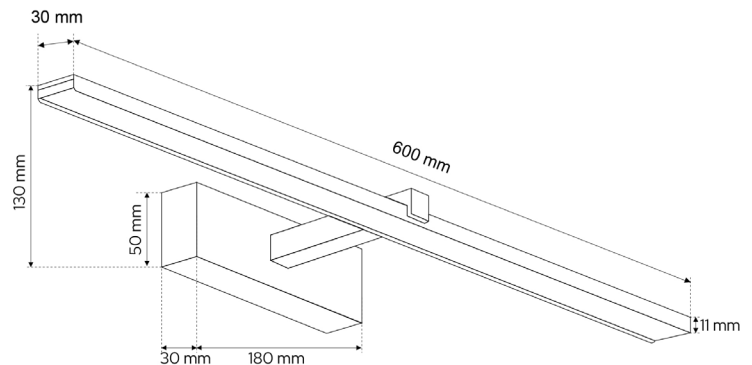

* The value has been rounded to whole numbers due to the requirements of the EPREL (European Registry for Energy Labeling) system